

Diode Production Testing with Series 2400 SourceMeter® Instruments

Introduction

Performing single-point pass/fail DC tests on packaged diodes is critical to ensure compliance with manufacturers' specifications and to identify and weed out defective devices before they are shipped. Most types of diodes undergo at least three basic DC parametric tests during this final inspection process: the Forward Voltage Test (V_F), Breakdown Voltage Test (V_R), and Leakage Current Test (I_R). While the reliability of these tests is essential to ensuring product quality, it's equally important that they be conducted quickly to maintain high production throughput.

Usually, several instruments are required to make these tests, such as a DMM, voltage source, and current source. However, as the number of instruments in the test system increases, the slower the overall measurement process becomes, reducing test throughput.

A system configured with a separate DMM and sources takes up substantially more rack space than a system built with all these functions in one unit. In addition to higher equipment costs, three separate instruments also mean there are three sets of commands to learn, complicating system programming and maintenance. Using multiple instruments and sources also makes trigger timing more complex and increases triggering uncertainty. Coordinating the operation of separate instruments also extends the measurement cycle by increasing the amount of bus traffic required, again decreasing throughput.

This application note describes how to configure a diode production test system using a single instrument that can source and measure both current and voltage — Keithley's Series 2400 SourceMeter® family (including the Model 2400 SourceMeter, Model 2410 High Voltage SourceMeter, and Model 2420 High Current SourceMeter) offers this capability. The three basic parametric tests for diodes are reviewed and algorithms for both the test system and IEEE-488 bus operation are outlined.

In addition to the three parametric tests (also referred to as functional tests), this application note includes a description of how to perform polarity testing on the diode. Polarity testing is often required on many of the newer surface mount diode packages, such as the Small Outline Diode (SOD) package. Such diodes do not automatically orient themselves in the same direction in a component handler, so the polarity of the device must sometimes be determined before beginning the full functional test sequence.

Two example programs for this application are available from Keithley's Web site. See the "Example Programs" section of this application note for more details on how to obtain copies of these programs.

Test Descriptions

Figure 1 illustrates the test points for each of the tests described.

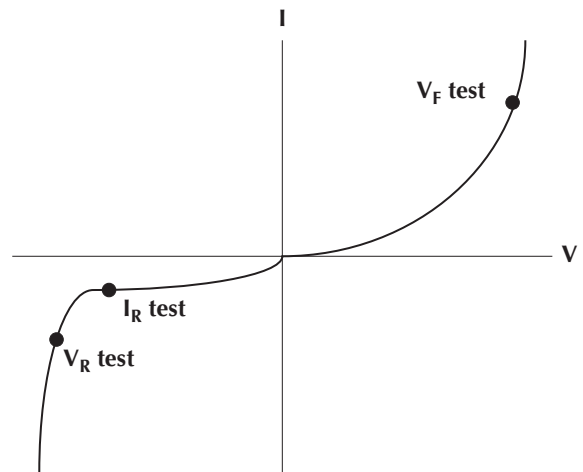

Figure 1. Typical Diode I-V Curve and Test Points (Not to Scale)

Polarity Test

The polarity test is designed to determine the orientation of the diode safely and quickly prior to completing functional tests on the device. The breakdown characteristics of the diode are used to generate an indication of the diode's polarity in one of two ways. A positive current can be sourced through the diode and the voltage measured. A voltage of less than 1V (typically) indicates forward polarity of the diode, while a high voltage indicates breakdown and reverse polarity. Alternatively, a negative current can be sourced, in which case a voltage measurement less than 1V indicates reverse polarity, while a high voltage indicates breakdown and forward polarity. The choice between these two methods for polarity testing depends primarily on the overall structure of the test program.

Forward Voltage Test (V_F)

This functional test involves sourcing a specified forward bias current within the normal operating range of the diode, then measuring the resulting voltage drop. To pass the test, the voltage must be within specified minimum and maximum values.

Reverse Breakdown Voltage Test (V_R)

In this test, a specified reverse current bias is sourced and the resulting voltage drop across the diode is measured. To determine whether the diodes pass or fail, the measurements are compared to a specified minimum limit.

Leakage Current Test (I_R)

The leakage test verifies the low level of current that leaks across the diode under reverse voltage conditions. This test is performed by sourcing a specified reverse voltage, then measuring the resulting leakage current. Good diodes will produce a leakage current that's less than or equal to the specified maximum value.

Test System Configuration

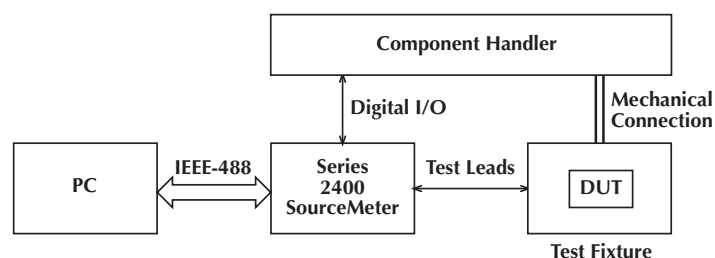

Figure 2. Block diagram of a SourceMeter-based system for diode production testing.

The diode or diode package is placed in a test fixture and connections are made to the input of the SourceMeter instrument. To prevent the generation of unwanted currents, use a test fixture that shields the diode from light. Using the IEEE-488 bus for control, the SourceMeter instrument powers and measures the diode. These measurements are then compared to pre-specified limits in the instrument and pass/fail determinations are made.

Output signals from the SourceMeter instrument's digital I/O port are used for interfacing with the handler to initiate diode orientation and/or binning. The instrument is equipped with four digital output lines that can be configured using Standard Commands for Programmable Instruments (SCPI). Each digital output code conveys a message, such as "part is good," "part is bad," "turn part," etc. The ability of the SourceMeter instrument to interface directly with the component handler frees the PC during handler control operations. This makes it possible for the computer to download and store test data while a new diode or diode package is being positioned in the test fixture. The example programs available from Keithley incorporate these features.

The three algorithms that follow describe diode testing under three different scenarios, depending on handler capability and diode package.

Diode Polarity Known

The following algorithm describes the operation of a Model 2400-based diode production test system to perform the measurements described when the polarity of the diode is known prior to functional testing.

1. Operator indicates to PC that a diode production lot is in place and ready for test.
2. PC initiates 2400 operation over IEEE bus. (See IEEE bus operation later.)
3. 2400 waits for Start of Test trigger from handler.
4. When the first diode is in position, the handler sends a Start of Test trigger signal to 2400, indicating first diode is ready for testing.
5. 2400 runs diode functional tests in the order stored in source memory, makes pass/fail determinations and saves data for each test: Forward Voltage Test, Breakdown Voltage Test, and Leakage Current Test.
6. 2400 sends overall pass/fail code and End of Test signal to handler and sends test data to PC (operations occur in parallel).
7. Repeat Steps 3–6 for remainder of diodes in lot.
8. 2400 returns to idle state. Operator installs new lot of diodes in handler.
9. Repeat Steps 1–8 as required.

Diode Polarity/Orientation Unknown—Component Handler Can Turn Device

The following algorithm describes the operation of a Model 2400-based diode production test system to perform the measurements described when the polarity of the diode is unknown prior to functional testing and the handler can turn the diode end for end.

1. Operator indicates to PC that a diode production lot is in place and ready for test.
2. PC initiates 2400 operation over IEEE bus. (See IEEE bus operation later.)
3. 2400 waits for Start of Test trigger from handler.
4. When the first diode is in position, the handler sends a Start of Test trigger signal to 2400, indicating first diode is ready for testing.
5. 2400 executes polarity test. If diode is verified in forward polarity, 2400 proceeds with functional tests. (step 6). If in reverse polarity, signal is sent to handler to turn the device and return to step 4.

6. Once the diode is in forward polarity, 2400 runs diode functional tests in the order stored in source memory, makes pass/fail determinations and saves data for each test: Forward Voltage Test, Breakdown Voltage Test, and Leakage Current Test.
7. 2400 sends overall pass/fail code and End of Test signal to handler and sends test data to PC (operations occur in parallel).
8. Repeat Steps 3–7 for remainder of diodes in lot.
9. 2400 returns to idle state. Operator installs new lot of diodes in handler.
10. Repeat Steps 1–9 as required.

Diode Polarity/Orientation Unknown—Component Handler Does Not Turn Device

This algorithm is slightly different from the previous one. It describes the operation of a diode production test system to perform the measurements described when the polarity of the diode is unknown prior to functional testing and the handler can not turn the device under test.

1. Operator indicates to PC that a lot of diodes is in place and ready for test.
2. PC initiates 2400 operation over IEEE bus. (See IEEE bus operation later.)
3. 2400 waits for Start of Test trigger from handler.
4. When the first diode is in position, the handler sends a Start of Test trigger signal to 2400, indicating first diode is ready for testing.
5. 2400 executes polarity test. If diode is verified in forward polarity, 2400 proceeds with functional tests using forward polarity parameters. (step 6a). If in reverse polarity, 2400 runs tests using reverse polarity parameters (step 6b).
- 6a. 2400 runs forward polarity diode functional tests in the order stored in source memory, makes pass/fail determinations and saves data for each test: Forward Voltage Test, Breakdown Voltage Test, and Leakage Current Test.
- 6b. 2400 runs reverse polarity diode functional tests in the order stored in source memory, makes pass/fail determinations and saves data for each test: Forward Voltage Test, Breakdown Voltage Test, and Leakage Test.
7. 2400 sends overall pass/fail code, diode polarity indicator, and End of Test signal to handler and sends test data to PC (operations occur in parallel).
8. Repeat Steps 3–7 for remainder of diodes in lot.
9. 2400 returns to idle state. Operator installs new lot of diodes in handler.
10. Repeat Steps 1-9 as required.

IEEE-488 Bus Operation

Here are some general guidelines to follow when writing a program to set up and execute the diode functional tests. As this general procedure indicates, each test set-up is stored in a Source Memory Location (SML). The Source Memory List of the Series 2400 instruments allows storing up to 100 test set-ups (49 when polarity must be determined) in individual SMLs. These tests can be executed in various sequences from one trigger over the IEEE bus. The instrument steps through the SMLs without computer intervention, thereby saving IEEE bus time and increasing system throughput.

The programming guidelines below assume polarity testing is not required. Additional guidelines for polarity testing follow separately.

1. Initialize GPIB and 2400.
2. Set 2400 parameters that will be common to all tests (e.g., autozero, data format, etc.)
3. Define the Forward Voltage Test.
 - a) Command 2400 to source current: set source range, value and delay.
 - b) Command 2400 to sense voltage: set measure range and compliance.
 - c) Set limit values and digital output bit patterns for each pass/fail outcome.
 - d) Save Forward Voltage Test configuration in Source Memory Location #1.
4. Define the Breakdown Voltage Test.
 - a) Command 2400 to source current: set source range, value and delay.
 - b) Command 2400 to sense voltage: set measure range and compliance.
 - c) Set limit values and digital output bit patterns for each pass/fail outcome.
 - d) Save Breakdown Voltage Test in Source Memory Location #2.
5. Define Leakage Current Test.
 - a) Command 2400 to source voltage: set source range, value and delay.
 - b) Command 2400 to sense current: set measure range and compliance.
 - c) Set limit values and digital output bit patterns for each pass/fail outcome.
 - d) Save Leakage Current Test in Source Memory Location #3.
1. Set Trigger Model for handler interface.
2. Initiate Testing.
3. Store Data.

An example program that illustrates this procedure is available from Keithley's World Wide Web site. For information on how to obtain a copy, refer to the section entitled "Example Programs."

Completion of polarity tests prior to functional testing requires some programming changes and additions to the basic guidelines previously listed. The specific changes are dependent on the type of handler used, as described earlier. For either scenario, however, the integration of the polarity test with subsequent functional tests is accomplished using the branching capability of the SourceMeter instrument's Source Memory List. This capability allows the user to program the instrument to execute different sequences of tests stored in Source Memory, depending on the outcome of the previous test. In this example, execution of functional tests proceeds in different ways, depending on the outcome of an initial polarity test.

Another SourceMeter instrument feature used in these test scenarios is the compliance limit test. For the polarity test, the compliance value of the instrument is set to a level that indicates diode breakdown and Limit 1 is activated to set a PASS/FAIL condition based on whether the voltage input reaches this compliance setting. This technique allows determination of diode polarity without the time required to perform an actual voltage measurement, thereby increasing test throughput.

Programming guidelines when polarity testing is required are covered below. An example program demonstrating the implementation of these guidelines is also available on the Keithley web site.

Handler With Capability to Turn the Diode

The IEEE bus operation for this configuration is similar to that for testing diodes of known polarity except for the use of additional Source Memory Locations (SMLs) and branching.

- SML 1 contains the polarity test, which is a reverse voltage test that is passed if the diode breaks down (i.e., compliance setting is reached), indicating forward polarity. Limit 1 is set for failure when the SourceMeter instrument is not in compliance.
- One of the SourceMeter instrument's four digital output lines is used to indicate to the handler when a diode must be turned to correct its polarity.
- SMLs 2, 3, and 4 are assigned as dummy test locations, needed simply to increment the Source Memory and trigger counters. These SMLs are executed only if a reverse polarity diode is encountered, i.e., SML 1 (polarity) test results in a FAIL condition.
- SMLs 20, 21, and 22 (or any other three sequential SML locations) hold the functional tests of Forward Voltage, Breakdown Voltage, and Leakage Current, which are executed when the SML 1 test results in a PASS condition.

Handler Without Capability to Turn the Diode

The IEEE bus operation for this configuration is similar to that for testing diodes of known polarity except for the use of additional SMLs and branching. However, it differs slightly from the previous procedure in its structure and use of digital I/O.

- SML 1 contains the polarity test, which is a forward voltage test that is passed if breakdown does not occur (instrument does not reach compliance), indicating forward polarity. Limit 1 is set for failure when the SourceMeter instrument is in compliance.
- SMLs 2, 3, and 4 are used to store the functional test settings for a diode in reverse polarity and are executed when the SML 1 test results in a FAIL condition.
- SMLs 20, 21, and 22 (or any other three sequential SML locations) are used to hold the functional test settings for a diode in forward polarity and are executed when the SML 1 test results in a PASS condition.

Switching Multiple Diodes

For diode arrays or multi-die packages, switching is required for connecting a single source-measure instrument to each of the individual elements. *Figure 3* is an example of a diode switching system test configuration. Actual systems can be configured for any number of diode elements and for various electrical specifications.

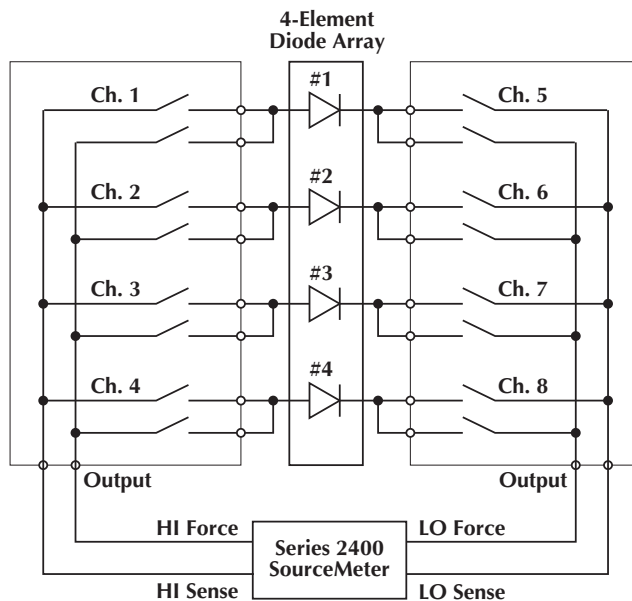

Figure 3. Switching multiple diodes to a Series 2400 SourceMeter instrument

Note that two 2-pole relays are used to connect each diode to the SourceMeter instrument. This is done to eliminate error from the voltage drop in the switch and lead resistance. This is particularly important when measuring the forward voltage because the measured voltages are relatively small (millivolts) and the source current is relatively high (milliamps).

To measure the forward voltage of diode #1, close channels 1 and 5, apply the specified current, and measure the resulting voltage drop. Next, perform the breakdown and leakage tests on diode #1 and then open channels 1 and 5. Close channels 2 and 6 to begin testing diode #2. Repeat this procedure for all the diodes.

Typical Sources of Error

Lead Resistance

A common source of voltage measurement error is the series resistance from the test leads running from the instrument to the diode. This series resistance is added into the measurement when making a 2-wire connection (See *Figure 4*). The effects of lead resistance are particularly detrimental when long connecting cables and high currents are used, because the voltage drop across the lead resistance becomes significant compared to the measured voltage.

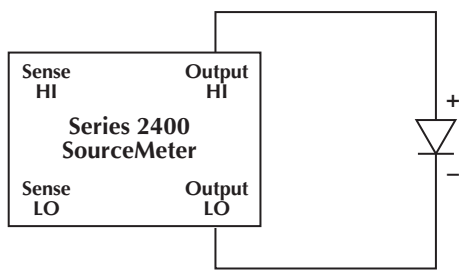

Figure 4. Two-wire connection

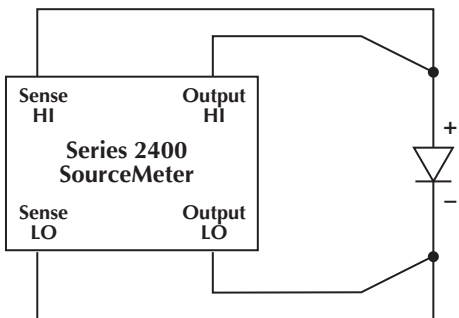

Figure 5. Four-wire connection

To eliminate this problem, use the four-wire remote sensing method rather than the two-wire technique. With the four-wire method (*Figure 5*), a current is forced through the diode using one pair of leads and the voltage across the diode is measured through a second set of leads. As a result, only the voltage drop across the diode is measured.

Leakage Current

Stray leakage in cables and fixtures can be a source of error in measurements involving very low currents, such as for leakage currents. To minimize this problem, construct test fixturing with high resistance materials.

Another way to reduce leakage currents is to use the built-in guard of the SourceMeter instrument. The guard is a low impedance point in the circuit that is nearly the same potential as the high impedance point to be guarded. This is best illustrated by example (*Figure 6*).

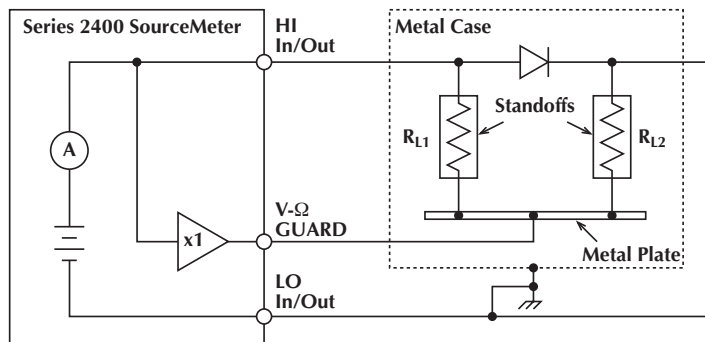

Figure 6. Series 2400 guarding technique

In this example, the diode to be measured is mounted on two insulated standoffs (R_{L1}). Guard is used in this circuit to ensure that all the current flows through the diode and not through the standoffs. In general, cable guard should be used when sourcing or measuring currents below $1\mu\text{A}$. This circuit is guarded by connecting the V-Ω Guard terminal of the instrument to the metal plate. This puts the bottom of insulator R_{L1} at almost the same potential as the top. Since both ends of the insulator are at nearly the same potential, no significant current can flow through it. All the current will flow then through the diode as desired.

WARNING: Guard is at the same potential as output HI. Therefore, if hazardous voltages are present at output HI, they are also present at the Guard terminal.

Electrostatic Interference

High resistance measurements may be affected by electrostatic interference, which occurs when an electrically charged object is brought near an uncharged object. To reduce the effect of electrostatic fields, a shield can be built to enclose the circuit being measured. As shown in *Figure 6*, a metal shield connected to ground surrounds the diode under test. The LO In/Out of the SourceMeter instrument must be connected to the metal shield to avoid noise due to common mode and other interference. This also acts as a safety shield because the metal plate is at guard potential.

Equipment List

The following equipment is required to assemble a diode production test system and run the example programs available from Keithley:

1. Keithley Model 2400, 2410, or 2420 SourceMeter instrument, with or without the contact check option
2. PC with KPC-488.2 Interface Card
3. Component handler with test fixture
4. Keithley 7007 IEEE-488 interface cable
5. Custom DB-9 digital I/O handler interface cable to interface the instrument to the handler
6. Test leads to connect the instrument to the test fixture

Example Programs

Keithley has developed three example programs to demonstrate the techniques described in this document. The first program executes the Forward Voltage, Breakdown Voltage, and Leakage Current Tests on five 1N914 switching diodes of known polarity. At the end of the test, an output report is produced that gives the test voltages, currents and pass/fail status. Be aware that this program may need to be modified depending on the type of handler used and its timing requirements.

The second and third programs illustrates the SCPI commands required for diode polarity testing under the two scenarios described here. The choice between these two options depends on the functionality of the handler used.

To obtain copies of these Example Programs as digital files, access Keithley's World Wide Web site (<http://www.keithley.com>).

Specifications are subject to change without notice.

All Keithley trademarks and trade names are the property of Keithley Instruments, Inc.

All other trademarks and trade names are the property of their respective companies.

KEITHLEY

Keithley Instruments, Inc.

Sales Offices: BELGIUM:

CHINA:

FINLAND:

FRANCE:

GERMANY:

GREAT BRITAIN:

INDIA:

ITALY:

JAPAN:

KOREA:

NETHERLANDS:

SWEDEN:

TAIWAN:

28775 Aurora Road • Cleveland, Ohio 44139 • 440-248-0400 • Fax: 440-248-6168

1-888-KEITHLEY (534-8453) • www.keithley.com

Bergensesteenweg 709 • B-1600 Sint-Pieters-Leeuw • 02-363 00 40 • Fax: 02/363 00 64

Yuan Chen Xin Building, Room 705 • 12 Yumin Road, Dewai, Madian • Beijing 100029 • 8610-82251886 • Fax: 8610-82251892

Tietäjäsentie 2 • 02130 Espoo • Phone: 09-54 75 08 10 • Fax: 09-25 10 51 00

3, allée des Garays • 91127 Palaiseau Cédex • 01-64 53 20 20 • Fax: 01-60 11 77 26

Landsberger Strasse 65 • 82110 Germering • 089/84 93 07-40 • Fax: 089/84 93 07-34

Unit 2 Commerce Park, Brunel Road • Theale • Berkshire RG7 4AB • 0118 929 7500 • Fax: 0118 929 7519

1/5 Eagles Street • Langford Town • Bangalore 560 025 • 080 212 8027 • Fax : 080 212 8005

Viale San Gimignano, 38 • 20146 Milano • 02-48 39 16 01 • Fax: 02-48 30 22 74

New Pier Takeshiba North Tower 13F • 11-1, Kaigan 1-chome • Minato-ku, Tokyo 105-0022 • 81-3-5733-7555 • Fax: 81-3-5733-7556

2FL., URI Building • 2-14 Yangjae-Dong • Seocho-Gu, Seoul 137-888 • 82-2-574-7778 • Fax: 82-2-574-7838

Postbus 559 • 4200 AN Gorinchem • 0183-635333 • Fax: 0183-630821

c/o Regus Business Centre • Frosundaviks Allé 15, 4tr • 169 70 Solna • 08-509 04 600 • Fax: 08-655 26 10

13F-3, NO. 6, Lane 99, Pu-Ding Road, Hsinchu, Taiwan, ROC. • 886-3-572-9077 • Fax: 886-3-572-9031